

5.9 MIPI—In Smart Agriculture

USE CASES

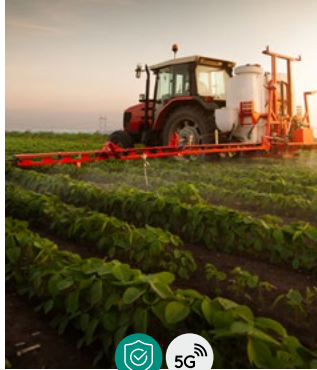

In Precision Agriculture:

- I3C over C/D/A-PHY physical interfaces to connect GPS sensors, electronic compass and actuators to AI application and CPU controlling pesticide and fertilizer dosage
- CSI-2 over C/D/A-PHY to enable machine-vision applications, checking crops for pest damage or disease
- RFFE within cellular communications module



In Livestock Monitoring:

- I3C to provide a shared, two-wire interface within livestock tracking devices connecting GPS and other sensors, to monitor animal health, activity and environmental impact; in-band interrupts used to enable low-power standby mode; and extended battery life
- RFFE within low-power, wide-area radio communications module



In Smart Greenhouses:

- I3C over A-PHY to connect heat, light, moisture, CO2 and other sensors, as well as actuators controlling temperature, airflow, irrigation and nutrient levels, ensuring optimal growth conditions
- A-PHY as a long-reach ($\leq 15m$), physical interface to connect sensors and actuators to a control unit
- DSI-2 over C/D-PHY for advanced, high-resolution control panel displays



In Automated Agricultural Machinery:

- I3C over A-PHY to connect the GPS, ultrasonic and other low-speed sensors, actuators and controls within the machine
- CSI-2 over C/D/A-PHY to connect high-resolution cameras, lidars and other high-speed sensors
- DSI-2 over C/D/A-PHY for connecting advanced, high-resolution displays
- A-PHY as a long-reach ($\leq 15m$), ultra-reliable physical interface, to enable safe operation in noisy EMI environments
- RFFE within cellular communications module

Automated Agricultural Machinery Schematic

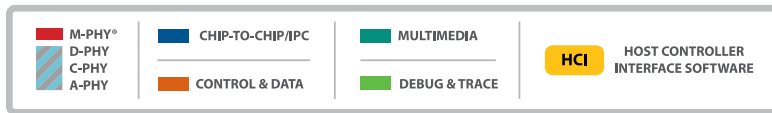
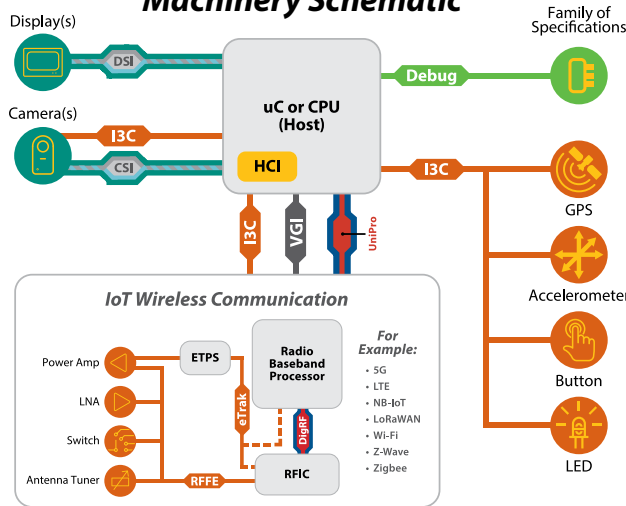

Associated MIPI SOFTWARE and DEBUG specifications also available to accelerate design process

Use of MIPI specifications can aid product compliance to functional safety standards such as IEC 61508

LEGEND

- Functionally safe and secure IoT device that will benefit from MIPI's focus on safety and security
- IoT device with constrained power supply that will benefit from use of MIPI low-power interfaces
- IoT device with wide-area cellular connectivity that will benefit from MIPI's 5G preparedness
- Size-constrained, tightly packaged IoT device, benefiting from MIPI's low pin count, low wire count, low EMI interfaces