

## 5.4 MIPI—In the Smart Factory

## USE CASES



### In Robots with Machine Vision:

- CSI-2 over C/D/A-PHY as a highly scalable interface to connect ultra-high-resolution cameras enabling low-power vision inferencing and machine vision
- A-PHY can be used in large machines as a long-reach ( $\leq 15\text{m}$ ), ultra-reliable physical interface, to link the robot to its control system in a noisy EMI environment
- I3C to provide a shared, two-wire interface to drive the sensors and actuators used to enable the robot

### In Machine Control Systems with Advanced UIs:

- DSI-2 over C/D/A-PHY to drive a high-resolution display
- MIPI Touch over I3C to enable an advanced touch-screen-based user interface
- I3C to provide a shared, two-wire interface to connect simple UI components such as push buttons, LEDs and buzzers
- A-PHY as a long-reach ( $\leq 15\text{m}$ ), ultra-reliable physical interface to link a control panel to the rest of the system in a noisy EMI environment, such as a factory

### In Automated Guided Vehicles (AGVs):

- CSI-2 over C/D/A-PHY as a highly scalable interface to connect multiple ultra high-resolution cameras, enabling low-power vision inferencing and machine vision for the AGV to navigate around the factory and avoid obstacles
- A-PHY as a long-reach ( $\leq 15\text{m}$ ), ultra-reliable physical interface, to link components within the AGV in a noisy EMI environment
- I3C to provide a shared, two-wire interface to drive the sensors and actuators required to control and drive the AGV
- RFFE within radio communications module

### In Industrial Tools:

- I3C to provide a shared, two-wire interface to connect switches, actuators driving motors, vibration sensors and simple UI components such as LEDs and buzzers
- RFFE within radio communications module

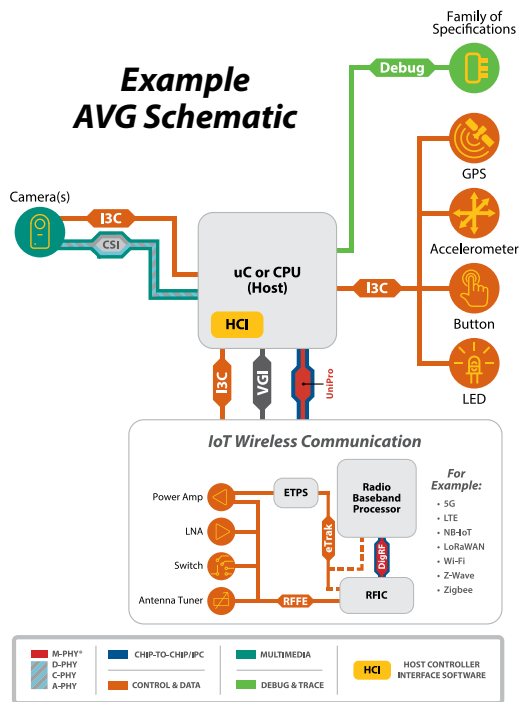

Associated MIPI SOFTWARE and DEBUG specifications also available to accelerate design process

Use of MIPI specifications can aid product compliance to functional safety standards such as IEC 61508

### LEGEND

- Functionally safe and secure IoT device that will benefit from MIPI's focus on safety and security
- IoT device with constrained power supply that will benefit from use of MIPI low-power interfaces
- IoT device with wide-area cellular connectivity that will benefit from MIPI's 5G preparedness
- Size-constrained, tightly packaged IoT device, benefiting from MIPI's low pin count, low wire count, low EMI interfaces