

5.1 MIPI—In the Smart Home USE CASES

MIPI specifications are also applicable to many other Smart Home use cases including:

- Home Automation
- Heating, Ventilation and Air Conditioning
- Home Security



In Home Hubs:

- SoundWire to provide a shared, two-wire interface to drive codecs, microphones and speakers. Enables noise cancellation, beam steering and low-power audio 'keyword' activation
- DSI-2 over C/D-PHY to drive a low-power, high-resolution display enabling display partitioning when device is in a low-power standby mode and a touchscreen user interface using MIPI Touch over I3C
- CSI-2 over C/D-PHY as a highly scalable interface to connect high-resolution cameras, enabling low-power vision inferencing and camera control using CCI over the same connector using USL
- I3C to provide a shared, two-wire interface to connect sensors and simple UI components
- UFS over UniPro/M-PHY for fast boot and to read and write high-resolution images
- RFFE within radio communications module

In Smart Doors:

- I3C to provide a shared, two-wire interface to connect fingerprint sensor, an actuator for the door lock and simple UI components such as dot matrix LED display. In-band interrupts can be used to enable low-power standby mode
- CSI-2 as a highly scalable interface to connect a high-resolution camera, enabling facial recognition using low-power machine vision inferencing
- SoundWire to provide a shared, two-wire interface to drive microphone and speaker, enabling low-power audio 'keyword' activation
- RFFE within radio communications module

In Smart Home Appliances:

- I3C to provide a shared, two-wire interface to connect all internal sensors and actuators, and to connect and drive simple UI components, such as LEDs and buzzers
- DSI-2 over C/D/A-PHY to drive a low-power, high-resolution display using display partitioning when the device is in standby mode and touchscreen user interface using MIPI Touch
- A-PHY can be used in large appliances as a long-reach ($\leq 15m$) physical interface, ensuring reliable connectivity in a noisy EMI environments, reducing the need for internal EMC shielding
- RFFE within radio communications module

Example Home Hub Schematic

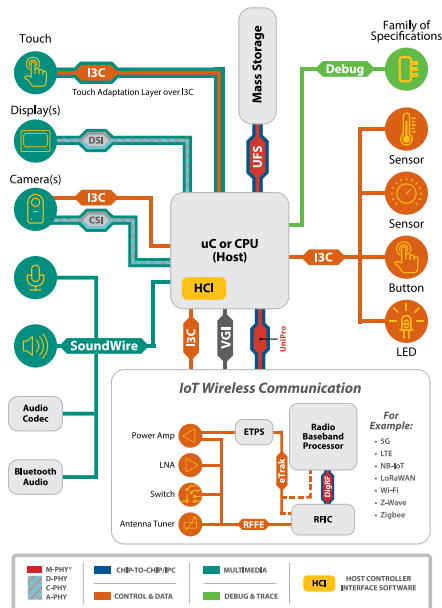

Associated MIPI
SOFTWARE and DEBUG
specifications also
available to accelerate
design process

LEGEND

- Functionally safe and secure IoT device that will benefit from MIPI's focus on safety and security
- IoT device with constrained power supply that will benefit from use of MIPI low-power interfaces
- IoT device with wide-area cellular connectivity that will benefit from MIPI's 5G preparedness
- Size-constrained, tightly packaged IoT device, benefiting from MIPI's low pin count, low wire count, low EMI interfaces